

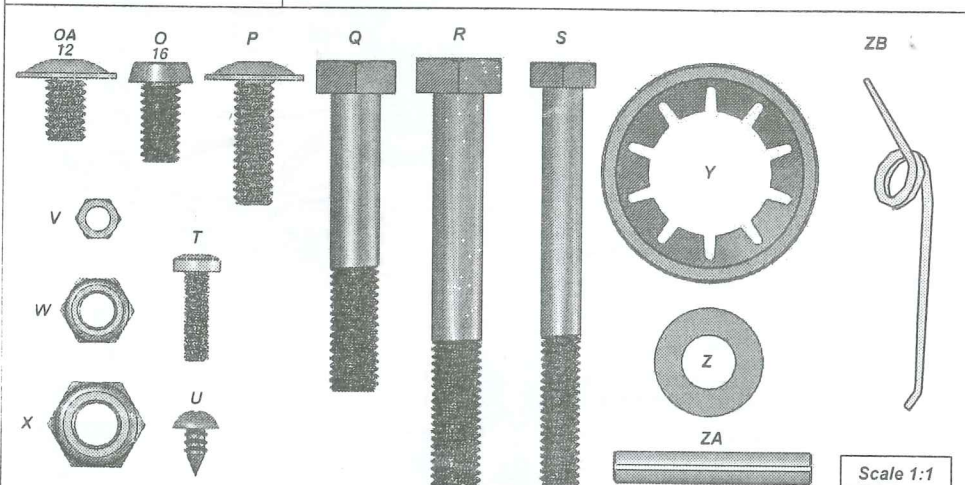

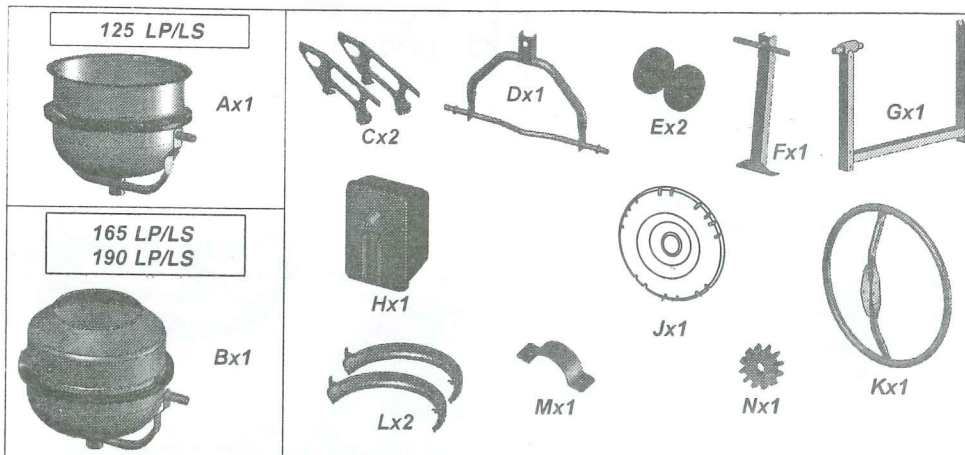

<b>125 LP/LS</b> <b>165 LP/LS</b> <b>190 LP/LS</b>	<b>HR</b>	<b>Mješalica za beton</b>	<b>Naputak za montažu</b>
	<b>GB</b>	<b>Concrete Mixer</b>	<b>Instructions for assembly</b>
	<b>D</b>	<b>Betonmischer</b>	<b>Montageanleitung</b>
	<b>F</b>	<b>Bétonnière</b>	<b>Instructions de montage</b>
	<b>I</b>	<b>Betoniera</b>	<b>Istruzione di montaggio</b>
	<b>РУС</b>	<b>Бетономеситель</b>	<b>Инструкция по сборке</b>
	<b>CZ</b>	<b>Míchačka na beton</b>	<b>Montážní návod</b>
<b>SK</b>	<b>Miešačka na betón</b>	<b>Montážny návod</b>	
<b>PL</b>	<b>Betoniarka</b>	<b>Instrukcja montażu</b>	
<b>ROM</b>	<b>Betonieră</b>	<b>Instructiuni de montare</b>	
<b>HU</b>	<b>Betonkeverő</b>	<b>Szerelési útmutató</b>	



Quantity	OA	O	P	Q	R	S	T	U	V	W	X	Y	Z	ZA	ZB
125 LP	0	12	4	1	4	4	0	2	0	20	5	2	4	1	1
125 LS	12	0	4	1	4	4	0	2	0	20	5	2	4	1	1
165 LP/LS	0	10	1	4	4	6	2	6	8	8	5	2	4	1	1
190 LP/LS	0	10	1	4	4	6	2	6	8	8	5	2	4	1	1
WITH PLASTIC PROTECTION								0							

**limex**  
 Altrad Limex d.o.o.

Altrad Limex d.o.o. HR - 31540 DONJI MIHOLJAC, CROATIA, Vukovarska 77, p.p.  
 T: 00385 /0/ 31 49 68 70, F: 00385 /08 31 49 68 71, e-mail: limex@limex.biz

	HR	Zatezanje alatom		HR	Ručno zatezanje		HR	2 osobe
	GB	Tightening with tool		GB	Manual tightening		GB	2 persons
	D	Werkzeugfestziehen		D	Handfestziehen		D	2 Personen
	F	Serrage avec outil		F	Serrage manuaie		F	2 personnes
	I	Serraggio con utensili		I	Serraggio manuale		I	2 persone
	PYC	Сборка с помощью инструментов		PYC	Ручная сборка		PYC	2 человека
	CZ	Upevnění pomocí nářadí		CZ	Upevnění ručně		CZ	2 osoby
SK	Upevnenie s pomocou náradia	SK	Ručné upavenenie	SK	2 osoby			
PL	Skręcać (łączyć) za pomocą narzędzi	PL	Skręcać (łączyć) ręcznie	PL	2 osoby			
ROM	Montaj manual cu chei	ROM	Montaj manual fara chei	ROM	2 persoane			
HU	Szerszámmal összeszerelendő	HU	Kézzei összeszerelendő	HU	2 ember			

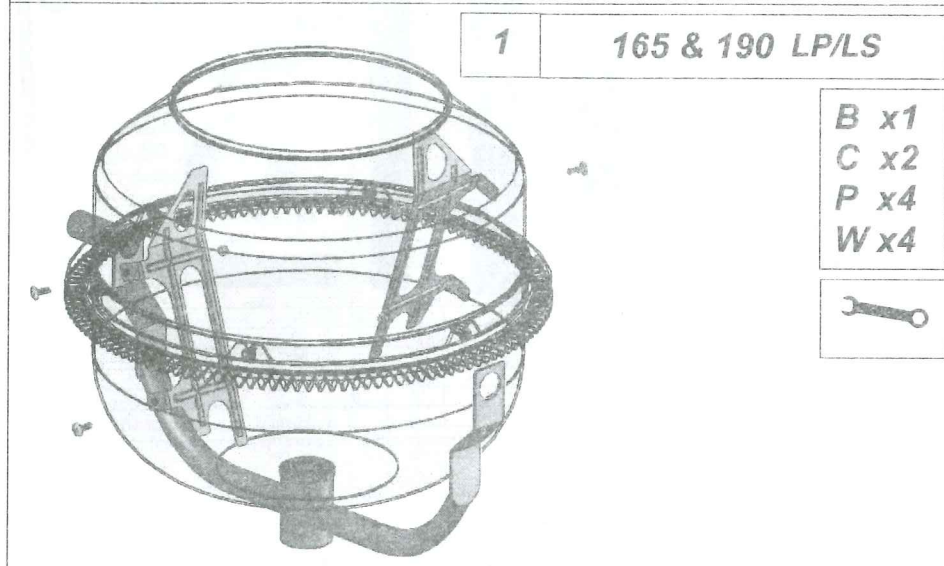
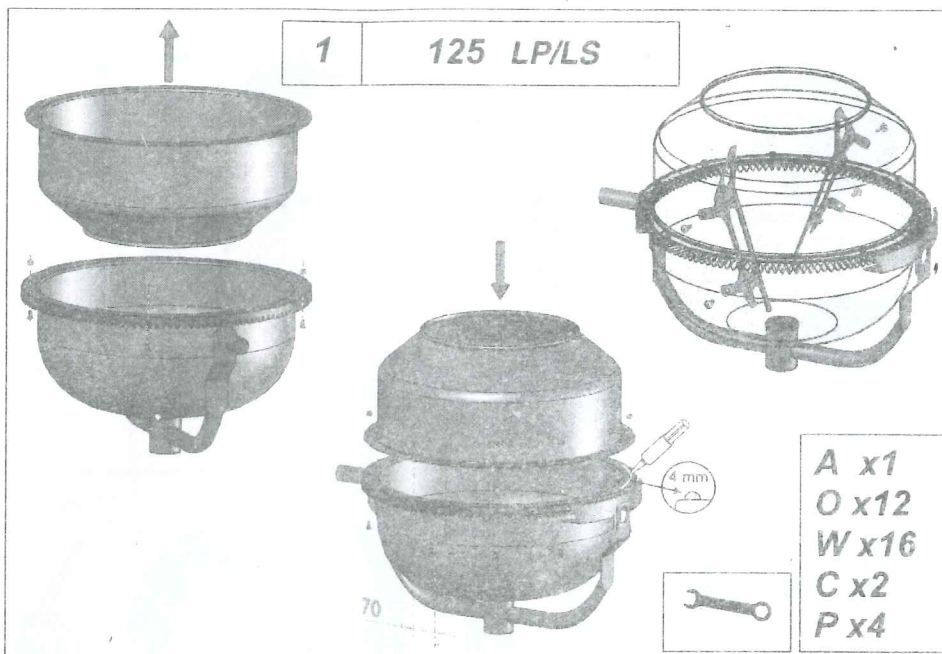

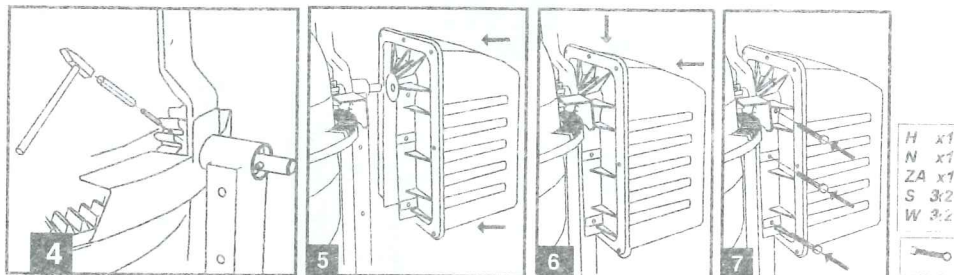
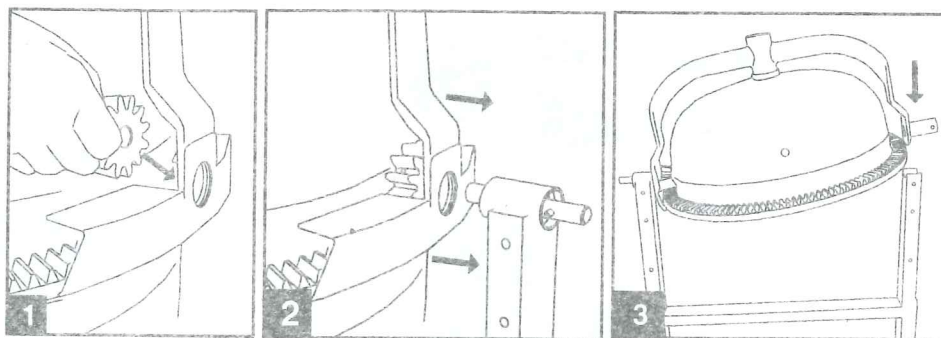
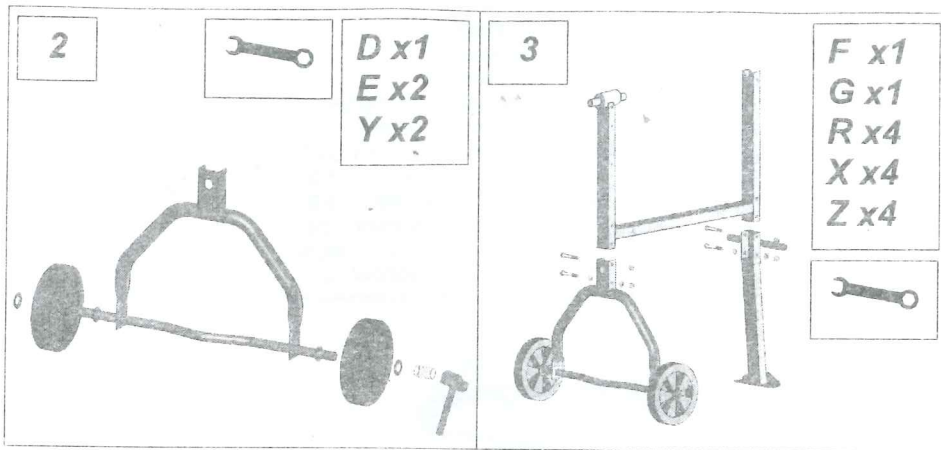

**HR** Slika 1. Rukom staviti mali zupčnik.  
Slika 2,3. Donji bubanj sa malim zupčnikom, prema slici 4. Montirati na vratilo uz pomoć zatika 6 x 40.  
Slika 4. Mali zupčnik čvrsto fiksirati na vratilo uz pomoć zatika 6 x 40.  
Slika 5. Montirati pogonsku kutiju na vratilo, vodeći računa o položaju zatika na vratilu.  
Slika 6. Završno rukom pritisnuti pogonsku kutiju prema dole i naprijed prema bubnju.  
Slika 7. Fiksirati kutiju za olivir mješalice uz pomoć 3 vijaka M8x80.

**F** PHOTO 1 – Poser le pignon d'entraînement manuellement.  
PHOTOS 2 et 3 – Monter la partie basse de la cuve avec le pignon d'entraînement sur la poulie, comme indiqué sur la photo 4.  
PHOTO 4 – A l'aide d'un marieau et au moyen de la goupille 6 x 40 qui vous est fournie, fixer le pignon d'entraînement sur la poulie.  
PHOTO 5 – Monter le bloc moteur sur la poulie en faisant attention à la position de la goupille sur la poulie.  
PHOTO 6 – Pousser manuellement le bloc moteur vers le bas, puis vers l'avant en direction de la cuve.  
PHOTO 7 – Fixer le bloc moteur sur l'arbre de la bétonnière au moyen des 3 écrous M8 x 80.

**ROM** 1: Introduceti manual piniorul in locului din  
2/3. Pozitionati partea de jos a cuvei impreuna cu piniorul conform imaginii 3 pozitionati axul motorului  
4: Fixati piniorul pe axul motorului cu ajutorul stiftului  
5: Montati carcasa motorului pe axul motorului avand in vedere pozitia stiftului pe axul motorului  
6: Daca este nevoie presati carcasa motorului prin miscari sus - jos catre cuva  
7: Fiksati carcasa motorului pe cartul betonierei prin cele 3 suruburi aferente

**GB** Picture 1: Manually put in small cogwheel.  
Picture 2/3: Lower part of the mixer drum, along with the small cogwheel according to the picture 3.  
Put up on the axle of the engine.  
Picture 4: Fix small cogwheel on the axle of the engine with inner pin it 6x40.  
Picture 5: Mount engine housing on the side of the engine with keeping in mind the inner pin position on the axle of the engine.  
Picture 6: Eventually, press the engine housing down and forward, toward the mixer drum.  
Picture 7: Fix the engine housing to the mixer's frame with 3 screws M 8x80.

**H** 1. kép: A kisfogaskereket beilleszteni.  
2,3. kép: A dob alsó részét beilleszteni a kisfogaskerekhez és rácsatlakoztatni a meghajtótengelyre.  
4. kép: A fogaskereket rögzítése (talapács segítségével) a meghajtótengelyre a zágengyűrű segítségével.  
5. kép: A motor óvalusan ráillesztani a meghajtótangelyre. Mindenképpen figyeljék közben a zágengyűrűt.  
6. kép: A komplett meghajtóházat lefelé a dob felé nyomni.  
7. kép: A motorház rögzítése 3 db csavarral (M8x80).

**D** BILD 1: Das kleine Zahnrad anlegen  
BILD 2,3: Die untere Trommelhälfte mit dem kleinen Zahnrad (Bild 4) verbinden und auf die Antriebswelle stecken  
BILD 4: Fixierung des kleinen Zahnrades (mit Hilfe des Hammers) mit der Seiltriebswelle mit Hilfe der Spannhülse fi 6x 40  
BILD 5: Den Motor vorsichtig auf die Antriebswelle setzen. Unbedingt die Lage der Spannhülse beachten.  
BILD 6: Zuletzt das komplette Gehäuse des Motors nach unten drücken und auch in Richtung Trommel drücken  
BILD 7: Fixierung des Motorgehäuses mit 3 Schrauben M8 x 80

**HR**

**POZOR!** Prije otvaranja kutije izvući mrežni utikač kabla mrežnog napona! Miješalica se smije staviti u pogon samo ako je poklopac kutije pogona montiran na okvir miješalice.

**GB**

**ATTENTION!** Before you open the housing, unplug the mixer. The mixer can be activated only when engine housing is mounted on the mixer's frame.

**D**

**ACHTUNG!** Vor dem Öffnen der Verkleidung Netzstecker ziehen! Der Mischer darf nur betrieben werden wenn die Verkleidung an den Rahmen des Betonmischers befestigt ist.

**F**

**ATTENTION!** Avant d'ouvrir le boîtier, débranchez la bétonnière de la prise de courant. Ne mettez la bétonnière en marche que lorsque le couvercle du boîtier du moteur est monté sur le boîtier à l'aide des vis prévues à cet effet.

**HU**

**FIGYELEM!** A doboz felnyitása előtt a hálózati feszültség hálózati kábelét kihúzni! A keverőgép csak akkor helyezhető üzembe, ha a meghajtó doboz fedelel fel van szerelve a keverő keretére.

**ROM**

**ATENȚIE!** Înainte de a desface carcasa motorului, scoateți betoniera din priză. Betoniera poate fi pusă în funcțiune numai după ce carcasa motorului este montat pe cadrul betonierei.

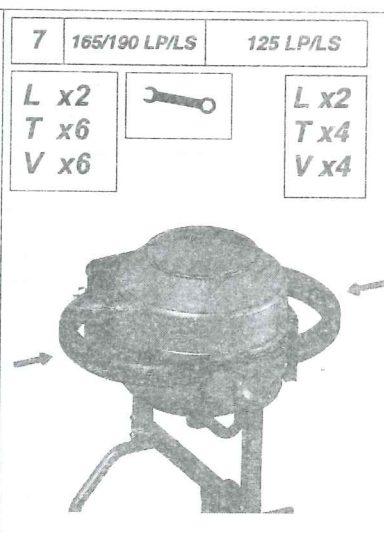
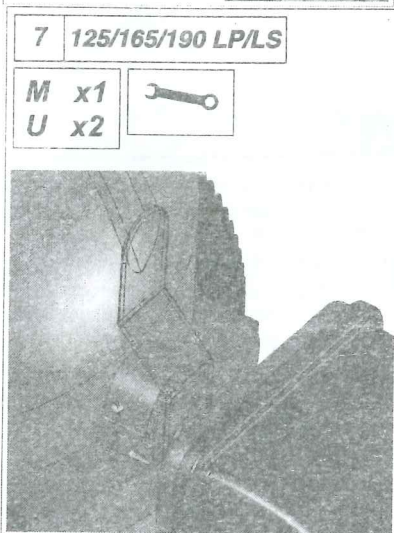
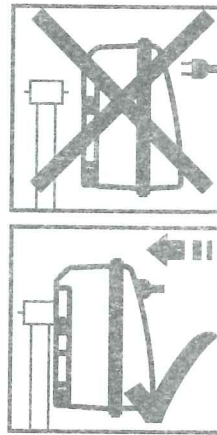
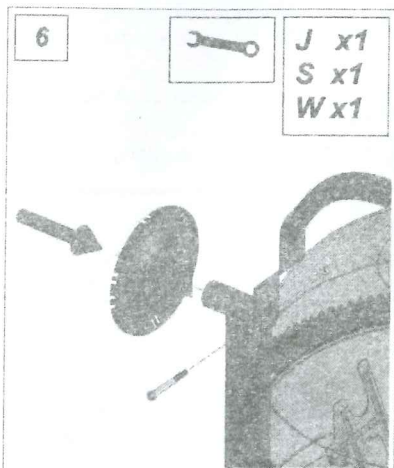

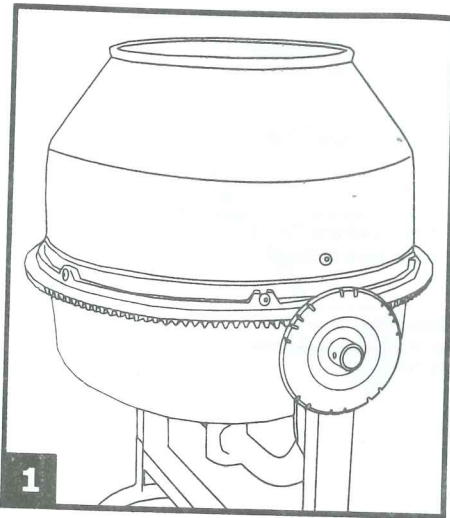

**HR** Postavite sklop bubnja i okretnog jarma na okvir mješalice.

**DE** Positionieren Sie die Trommel und den verstellbaren Bügel auf den Rahmen des Betonmischers.

**FR** Placé la cuve avec etrier sur chasis.

**GB** Put the drum and drum holder assembly into the mixer frame.

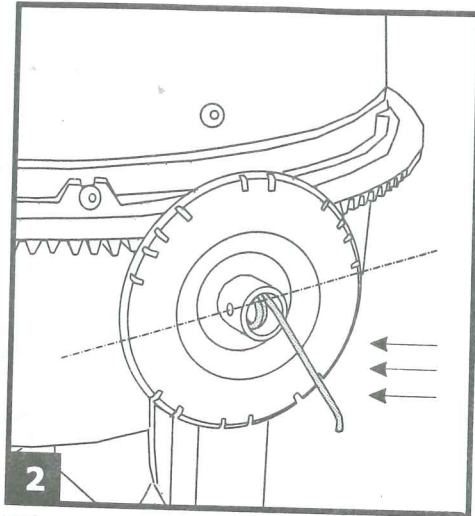

**HR** Uložiti dvokraku oprugu u cijev.

**DE** Vor der Montage des Handrades die Spiralfeder mit den 2 Windungen einsetzen.

**FR** Implanté ressort avec 2 tenticules dans la tube.

**GB** Insert two-arm frame spring in tube.

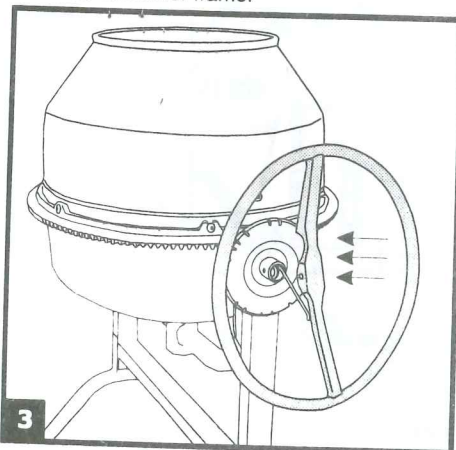

**HR** Pozicionirati ručno kolo.

**DE** Positionieren Sie das Handrad.

**FR** Positioné le volant.

**GB** Put the position for manipulation ring.

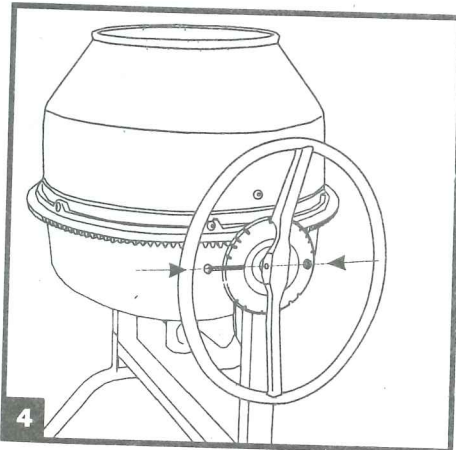

**HR** Pričvrstite ručno kolo i cijev prema slici. PAZITI pri tom da vijak prođe kroz spiralni dio opruge. Zategnuti vijak.

**DE** Das Handrad entsprechend der Zeichnung befestigen. Bitte beachten, daß die Befestigungsschraube durch die Mitte der Spiralfeder geführt wird.

**FR** Fixé le volant et la tube selon la photo. Faire attention que vis passe par la partie spirale de ressort. Serré la vis.

**GB** Tighten the manipulation ring and tube according to the picture. Please be careful that screw must pass through the spiral part of spring. Tighten the screw.

HR	Rezervni dijelovi
GB	Spare parts
D	Ersatzteilen
F	Pièces de rechange
I	Pezzi di ricambio
РУС	Запасные части
CZ	Náhradní díly
SK	Náhradné diely
PL	Części zamienne
ROM	Piese schimb
HU	Cserealkatrészek

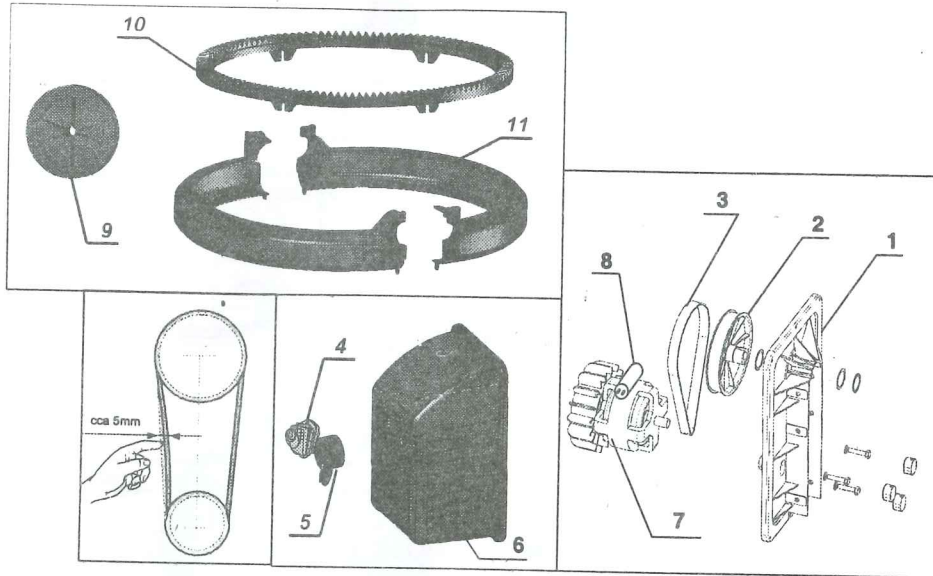

	125		165		190
	125 LP	125 LS	165 LP	165 LS	190 LP
1	Engine box back	016277	016277	016277	016277
2	Pulley + Elastic pin	021517+ 021512	021517+ 021512	021517+ 021512	021517+ 021512
3	Transmission Belt	021503	021503	021503	021503
4	Switch	016370	016370	016370	016370
5	Socket	022165	022165	022165	022165
6	Engine box cover	014260	014260	014260	014260
7	Engine	021496	021496	021496	021480
8	Condenser	022383	022383	022383	016178
9	Wheel 240/25 x 40	014585	014585	014585	014585
10	Crown Wheel	014124	021501	014125	022490

 **limex**  
Altrad Limex d.o.o.

Altrad Limex d.o.o. HR - 31540 DONJI MIHOLJAC, CROATIA, Vukovarska 77, p.p.  
T: 00385 /0/ 31 49 68 70, F: 00385 /08 31 49 68 71, e-mail: limex@limex.biz